



FLOW  
LEVEL  
PRESSURE  
ANALYTICAL  
TEMPERATURE  
INSTRUMENTATION  
PASTEURIZATION CONTROLS

## "HM" Turbine Flowmeter

### FEATURES:

- *Durable stainless steel shaft and rulon sleeve bearing eliminates frequent rebuilding and reduces maintenance*
- *All 316 stainless steel construction, including rotor*
- *Two piece design allows for easy access to internals for inspection*
- *3-A compliant; Third party verified in accordance with standard 28-03*

Anderson's HM-series turbine flowmeter is the solution for applications requiring an economical, accurate flowmeter. Using the proven method of counting the rotation of a turbine within a flowing stream of liquid, the "HM" turbine flowmeter is not merely a modification of an industrial design, but a design that was created specifically for the sanitary food and dairy industry.

Understanding these requirements has produced a flowmeter with superior

durability in the unique applications found in that industry. An all 316SS construction (including rotor) coupled with a unique two piece design which eliminates the need for internal locking rings to retain the meters internals makes for a truly cleanable, hygienic design that also provides exceptional performance.

Non-magnetic sensing of the 316SS rotor eliminates the drag other magnetically sensed rotors experience which provides for better metering accuracy and greater

longevity. The HM can handle aggressive products such as acids, vinegar solutions, brine, and de-ionized water.

Complete specifications and ordering information are available on the reverse. For more information please visit our Web Site at [www.andinst.com](http://www.andinst.com), or contact your local Authorized Anderson Distributor.

### APPLICATIONS

- Water
- Vinegar
- Light Oils
- Beer
- Alcohols
- Brine Solutions
- Filtered Wine
- De-ionized Water
- CIP Solution
- Clear Juices



# HM Specifications

Connections: Sanitary Clamp Connections  
 Construction: Body - 316 Stainless Steel  
 Rotor - 316 Stainless Steel (optional 17/4 PH)  
 Sleeve Bearing - Rulon 123  
 Gasket - Viton Rubber

Maximum Product Temperature: 250°F(120°C)  
 Maximum Inlet Pressure: 115psi / 7.9 bar  
 Maximum Product Viscosity: 100 cps  
 Power Supply: 9-30 VDC  
 Signal Output: 10-22 VDC  
 Accuracy: ± 0.50% Over Entire Flow Range  
 Repeatability: ± 0.10%  
 Flow Rates:  
 HM-075 5-17 GPM  
 HM-100 7-70 GPM  
 HM-150 13-130 GPM  
 HM-200 25-250 GPM

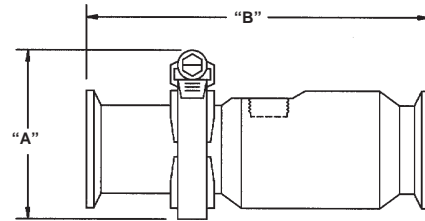

FIG. 1 - SIDE VIEW

**DIMENSIONS:**

MODEL	Dim "A"	Dim "B"	FITTING
HM-075 HM-100	2.88	5.88	1" T.C.
HM-150	3.25	6.13	1 1/2" T.C.
HM-200	3.75	8.63	2" T.C.

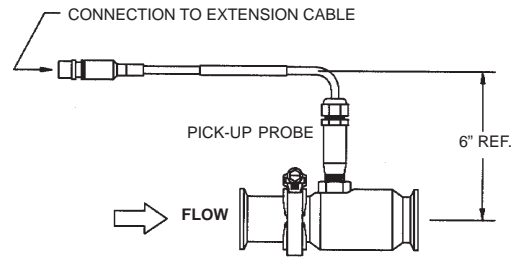
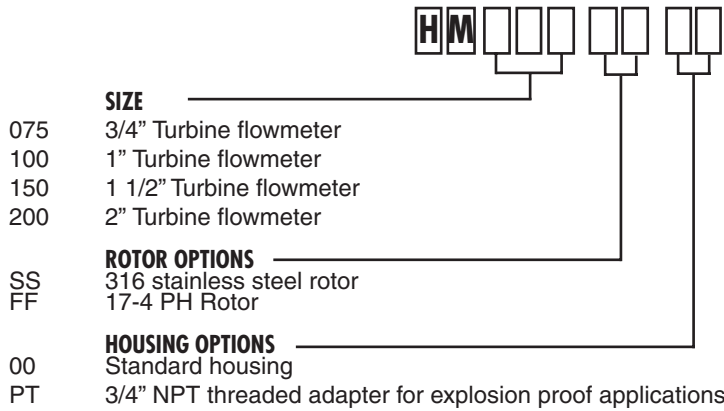
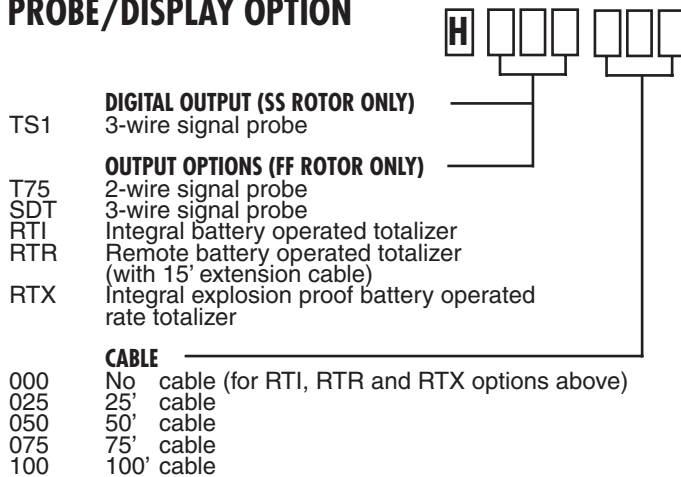

FIG. 2 - SIDE VIEW with PROBE ASSEMBLY

## HOW TO ORDER



## PROBE/DISPLAY OPTION



## Replacement Parts

Part Number	Description
HTS1000	3-wire pick-up probe
HT75000	2-wire pick-up probe
HSDT000	3-wire pick-up probe
HM600-075SS	3/4" Rebuild kit 316 SS rotor
HM600-100SS	1" Rebuild kit 316 SS rotor
HM600-150SS	1.5" Rebuild kit 316 SS rotor
HM600-200SS	2" Rebuild kit 316 SS rotor
HM600-075FF	3/4" Rebuild kit 17-4 rotor
HM600-100FF	1" Rebuild kit 17-4 rotor
HM600-150FF	1.5" Rebuild kit 17-4 rotor
HM600-200FF	2" Rebuild kit 17-4 rotor