



P R E S S U R E
T E M P E R A T U R E
L E V E L
I N S T R U M E N T A T I O N
F L O W
A N A L Y T I C A L

"LA" Level Transmitter

Top-mount, "dipstick" style transmitter for level control applications!

- *Top-mount configuration provides for easy installation without special fixturing or welding*
- *Micro-processor based platform*
- *No moving parts for highest reliability and cleaning in-place*
- *Quick Disconnect Receptacles with optional Field Wiring Connectors*
- *Standard lengths from 15" to 72" adaptable to any existing vessel*

Hundreds of customers have proven for themselves that the Anderson's dual-diaphragm technology level transmitters are the clear choice for monitoring liquid inventory levels in virtually any atmospheric storage application. But, what about:

- Level applications where bottom access is not available?
- Sterile applications where a seal in the product contact zone is not preferable?
- Ball-float sensors that can't measure to the bottom of the vessel?
- Other top-mount solutions that fail unexpectedly due to probe coating, lack of conductivity, and mechanical failure?

For these tough applications, Anderson now offers the "LA" series of top-mount level transmitters. The design is based on our proven "SX" platform which provides the industry's best accuracy, temperature stability, and reliability. The "LA" is simple to specify, install and calibrate. It easily replaces problematic devices such as ball floats, pneumatics, capacitance probes and magneto-strictive sensors. It pays for itself almost immediately by providing more accurate fill levels with less downtime for cleaning and maintenance.

So, if you have an application like one described above and want to see how the "LA" will provide the kind of reliable control you've always wanted, give us a call.



LA Specifications

Performance

Upper Range Limit (URL): 72" water column (w.c.)
 Minimum Span: 30" w.c.
 Over-Range Capacity: 2.5 times the URL (180" w.c./6.5 psig)
 Accuracy: ± 0.75% of URL (± 0.5" w.c.)
 Repeatability: within ±0.3% of URL (± 0.2" w.c.)
 Stability: Within published specification for one (1) year minimum
 Compensated Temp. Range: -1°C to 104°C (30°F to 220°F) (process)
 Compensated Temp. Range: -1°C to 49°C (30°F to 120°F) (ambient)
 Effect of Process/Ambient Temperature Change: ± 0.40% of URL per 10°F
 Humidity: 0-100% RH, Condensing
 Response Time: 526 mSec

Power Signal

Output: 4-20mA dc
 Loop Power required: 12-40 Vdc
 Effect of Voltage Change: ± 0.05% of URL per 30 volts
 Load Impedance: 1400 Ohms at 40 Vdc
 Cable Recommended: 2 conductor, stranded, 18-24 AWG, shielded with ground
 0.17 - 0.26" Cable Sheath OD for use with field wiring connector
 Receptacle: Turck minifast® 3-pin, NEMA 4X/IP65 connected or disconnected

Materials/Construction

Housing /Wiring Head: 304 stainless steel
 Wetted Parts: 316L stainless steel
 Surface Finish: $R_a=15$ microinches or better (wetted parts)
 Housing Rating: NEMA 4X, IP-65

Agency Approvals

Electromagnetic Compatibility (EMC): CE Compliant

Sanitary Standards: 3-A compliant; Third party verified in accordance with standard 74-02

Designed and manufactured to sound engineering practices in accordance with Article 3.3 of the PED 97/23/EC

Hazardous Locations: Intrinsically safe for use in Class1, Div. 1 Groups A-D

Warranty: All units are covered by a two (2) year warranty against defects in material and workmanship when installed and maintained according to the instruction manual provided
 Certifications: Certification of calibration provided

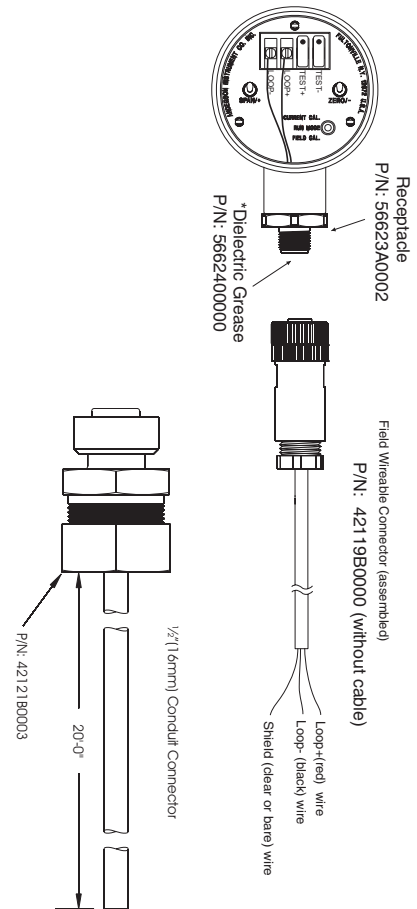
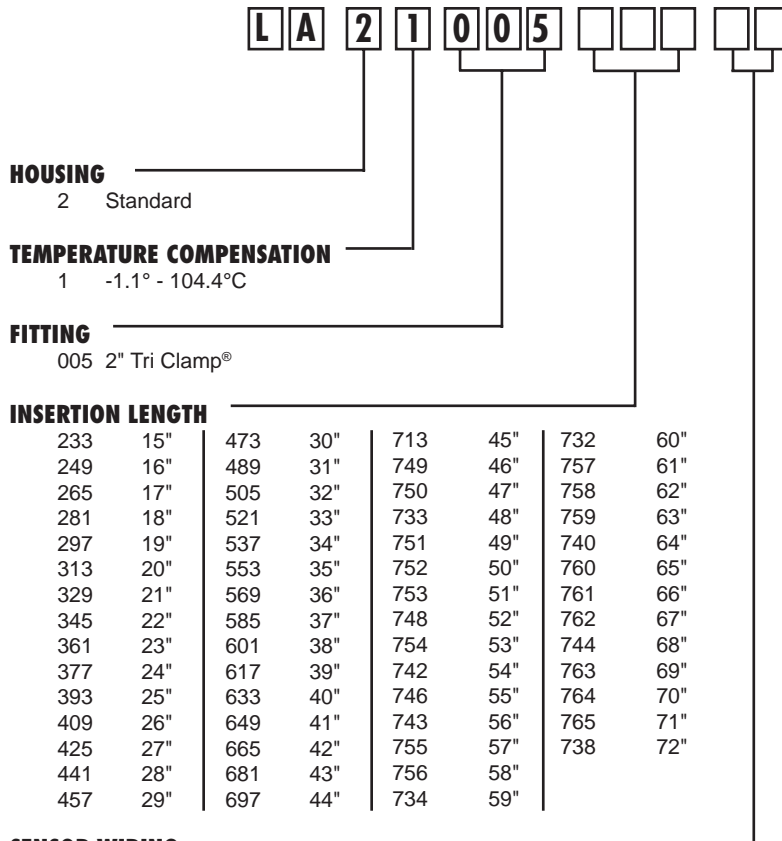

SENSOR WIRING

- | | |
|--|--|
| 00 Quick Disconnect Receptacle (QDR) w/No Cable | 21 QDR & FWC w/125 ft Cable |
| 01 QDR & Field Wireable Connector (FWC) w/No Cable | 22 QDR & FWC w/150 ft Cable |
| 05 QDR & FWC w/25 ft Cable | 23 QDR & FWC w/175 ft Cable |
| 10 QDR & FWC w/50 ft Cable | 24 QDR & FWC w/200 ft Cable |
| 15 QDR & FWC w/75 ft Cable | 98 QDR and Liquid Tight Flex 1/2" (16mm) Conduit Connector w/20 ft Cable |
| 20 QDR & FWC w/100 ft Cable | 99 No QDR, no FWC and no Cable (No sensor warranty for water damage) |