

MURZAN PI 50

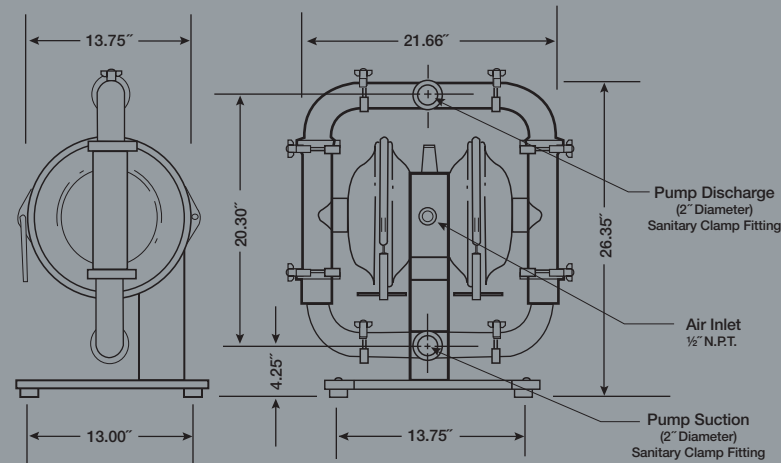

MURZAN

SANITARY PUMPS

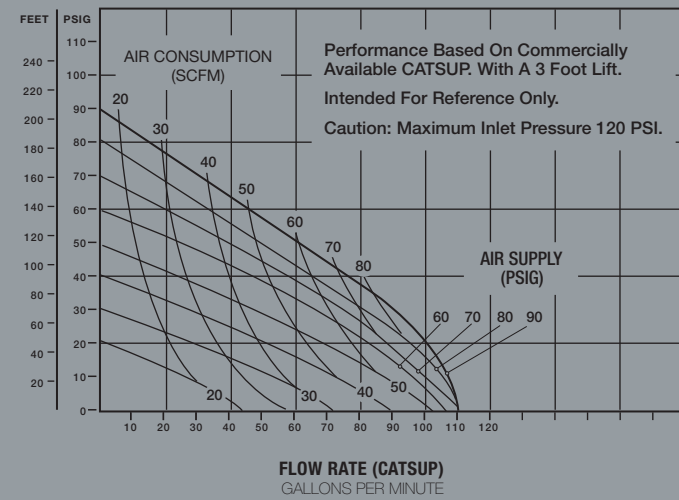
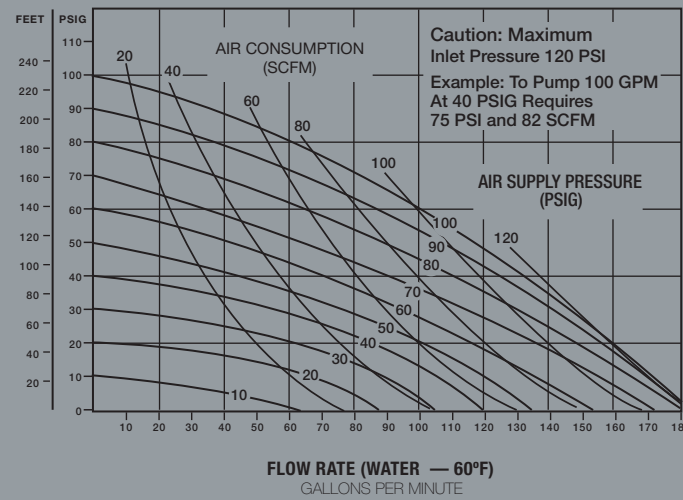

MURZAN

United States
 2909 Langford Road. I-700
 Norcross, GA 30071
 Tel: (770) 448-0583
 Fax: (770) 448-0967
 murzan@murzan.com
 www.murzan.com

Europe
 Orly Frêt B.P. 617
 Zone Juliette Bât. 127D
 94392 Orly Aéroport Cedex
France
 Tel: +33 (0) 1.49.75.51.52
 Fax: +33 (0) 1.49.75.51.53
 info@murzaneurope.com
 www.murzan.com

Mexico
 Coscomate 199
 Col. Bosques de Tetlameya
 México D.F. 04730
Mexico
 Tel: 525 55 528-2357
 Fax: 525 55 665-2217
 murzanmexico@prodigy.net.mx
 www.murzanmexico.com.mx

The Murzan PI50 Sanitary Pump Gently Handles the Widest Range of Viscosities and Particle Sizes Up to 6” (15 cm)

The **Murzan PI 50** is the only diaphragm pump specifically designed to meet the special requirements of sanitary industry. High efficiency oil free air valve, hygienic ball check system, guided ball, or flap check valve and total visual inspection of all wetted parts, give the user safe and efficient transfer of foods, cosmetics and pharmaceuticals — USDA equipment acceptance certificate, FDA approved, the PI 50 Series is manufactured to meet general 3-A standards and available as EHEDG certified.

Construction

PI 50 DL – 304 SS Wetted Parts

PI 50 SL – 316 SS Wetted Parts

All wetted parts polished to number 4 finish – 180 grit. Even non-wetted parts such as the air chambers are also polished. Pump center block on all models is 316SS. Food grade BUNA N is Standard for diaphragms, gaskets and valve balls; other elastomers are also available. The base is constructed of polished 304SS and is equipped with rubber feet. Mobility option with casters is available.

Suction and Discharge

Sanitary clamp connections are standard. Other connection types are optional. Sizes: 1½”x1½”, 2”x2”, 3”x2”, 3”x3”, and 4”x4”. Ball check, guided balls (mushroom), or flap check valves.

Ease of Cleaning

Our unique design allows for total visual inspection of all wetted parts. There are no blind spots or hidden areas for bacteria to grow in. Simply remove the manifold clamps and chamber clamps for complete disassembly and cleaning. Our sanitary quick clamps reassemble the PI50 in minutes for a minimum of down time. Easy to clean manually and sanitize or to clean in place (C.I.P.).

Murzan pumps can be supplied with three types of check valves: the ball, guided ball (mushroom) or flapper valves. This allows for easy interchangeability of the valves to cover the full range of pumping applications from viscous products, to solids suspended in liquids or solids suspended in viscous products warranting the best result on gentle handling with practically no damage either in viscosity or particulate integrity of your product.

Oil Free Air Directional Valve

The PI 50 oil free air directional valve needs no lubrication. The possibility of environmental or product contamination is totally eliminated. Constructed of self-lubricated materials, the valve operates horizontally with a minimum of friction losses. This patented feature allows the valve to activate under a 10 PSI differential pressure. The efficiency of the valve gives high performance at lower input air pressure. The result is a lower cost to you per gallon or liter of product pumped.

Anti-Freezing Design*

Our mechanically activated and adjustable anti-freezing feature allows our air directional valve to function perfectly under the most adverse operating conditions. With the PI 50 there is no need to add anti-freezing solutions to the air supply. No possibility of environmental contamination caused by these additives.

Advantages of the PI 50 DL

- Self priming up to 24 feet
- Costly drives and special motors are not required
- No mechanical seals to replace
- Light in weight, 94 lbs. – it can be moved to the application
- Run dry without damage
- Fewer parts than other available pumps
- For portable & permanent installations
- Infinitely variable flow control
- Solids up to 6” (15 cm)
- Handles abrasive product
- Delicate to shear sensitive fluids
- Viscosities up to 150,000 CP or higher if product is self leveling

Applications Like:

- Cottage Cheese
- Orange Juice Concentrate
- Yogurt • Ice Cream Toppings
- Tomato Sauce and Paste
- Vegetable Soups
- Fruit Juice Concentrates
- Macaroni Salad and Ravioli

- Fruit Slices and Whole Berries
- Mustard • Mayonnaise
- Pineapple Chunks
- Diced Tomatoes
- Ground Beef
- Relish • Catsup
- Pie Fillings • Yeast
- Hard Boiled Eggs
- Barbecue Sauces
- Salad Dressings

Industries

- Food Industry
- Meat & Poultry Industry
- Beverage Industry
- Egg Processing Plants
- Cosmetic Industry
- Pharmaceuticals and Biopharma
- Dairy Industry
- Frozen Foods
- Baking Industry
- Health Care
- Pet Food

